



**NDB (Non-Directional-Beacon)
Radio Transmitter**

ALL-IN-ONE !

**NEW GENERATION NDB WITH ULTIMATE
CAPABILITY
EASY AND LOW COST INSTALLATION
COVERS WORLDWIDE NDB SPECIFICATIONS**



TELE SUPPLY A.S

Fetveien 300, N-1900 FETSUND, NORWAY.

Telephone: +47 63 88 43 99

E-Mail: post@telesupply.no

Org.nr.: NO 935787610 MVA

<http://www.telesupply.no>



Transmitter Cabinet

IP66 protected

PC display

Control & Monitoring

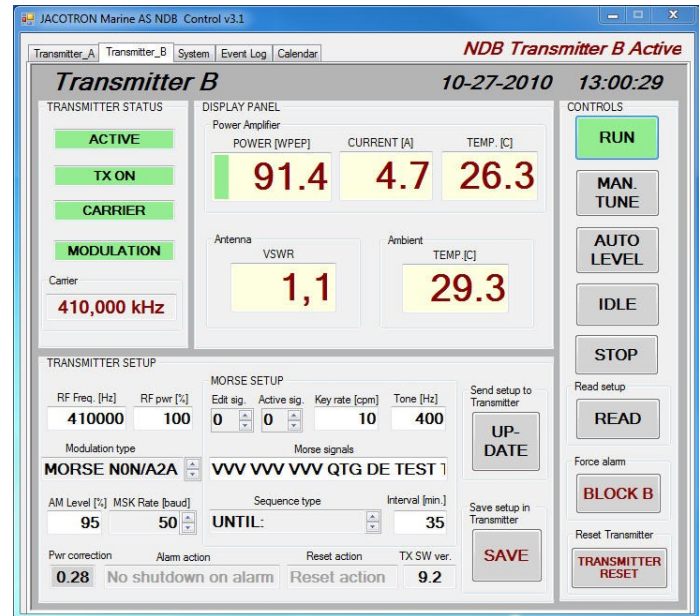
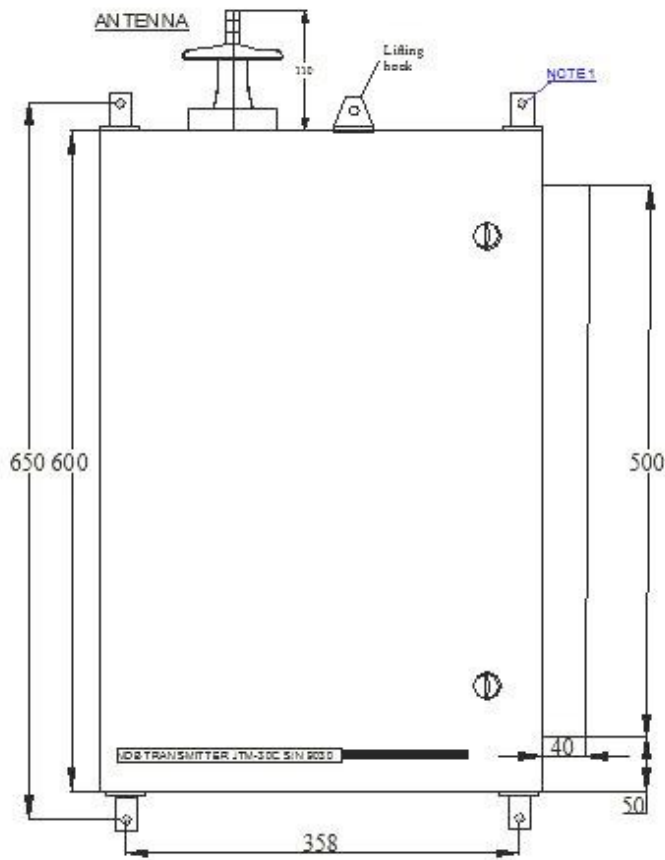

NDB Exciter



NDB Remote Control

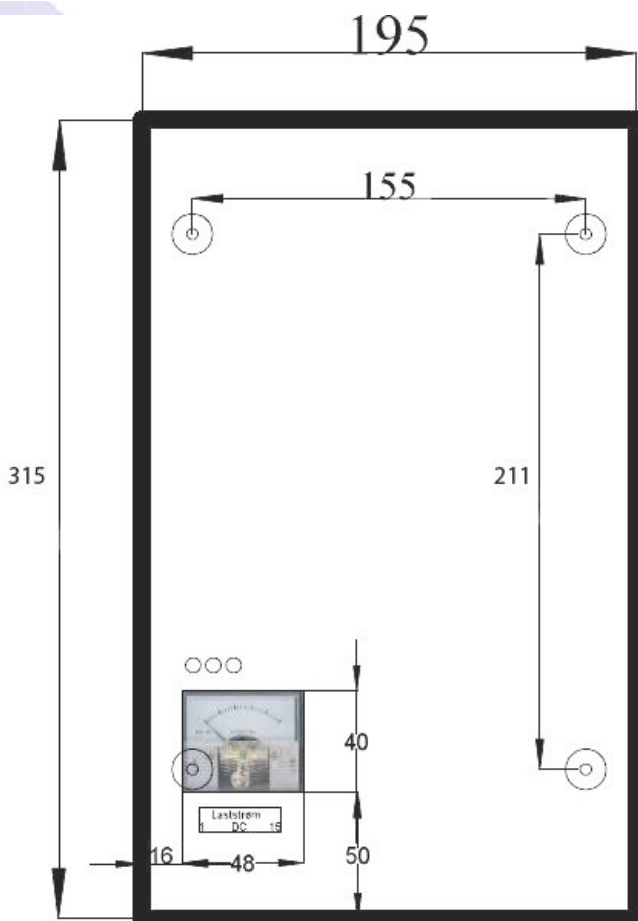

JTM-30C TRANSMITTER CABINET

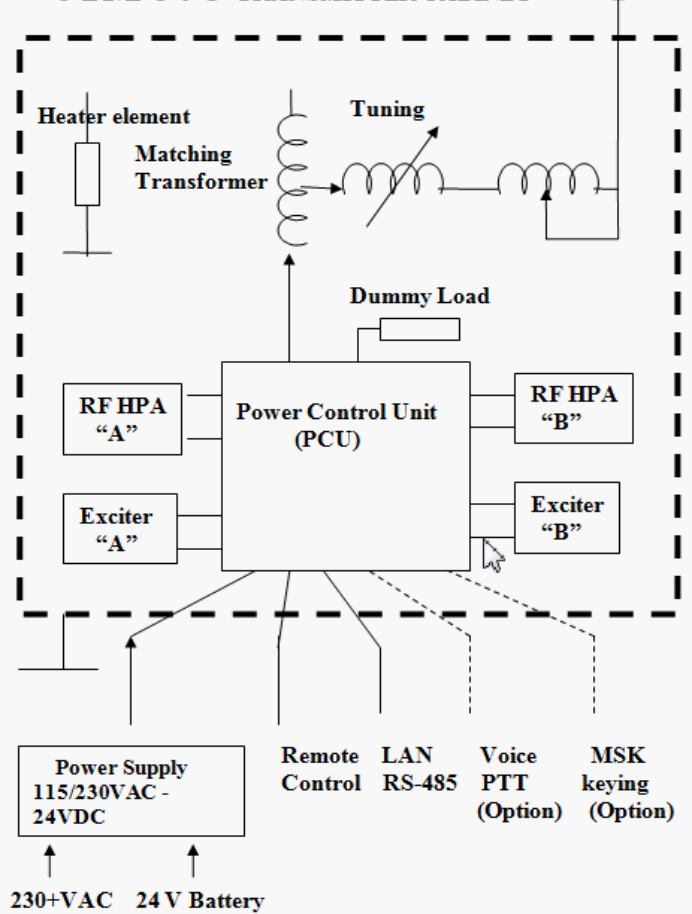

NDB Non-Directional Radio Beacon

The JACOTRON Marine JTM-30C is a Non-Directional Radio Beacon (NDB) Transmitter designed for onboard use on oilrigs and ships, as well as for other applications.

The JTM-30C is available IN two different versions:

Single NDB Transmitter configuration with one complete transmit chain

Redundant NDB Transmitter. This configuration has two complete transmitter chains with fault detection/reporting and automatic changeover.

Both versions are built upon a totally new concept for NDB transmitters utilizing digital Exciters. The transmitters have the following main features:

The carrier frequency may be tuned in steps of 1 Hz from 190 kHz to 2MHz. The output power is 100W Peak Envelope Power (PEP) max. The Exciter provides full power control of the carrier. Frequency generation by Direct Digital Synthesis featuring high linearity and stability of carrier and modulation, low noise and excellent frequency accuracy.

The transmitters operate with N0N/A2A or N0N/A3A emission. MSK modulation is available as an option.

A Timer function enables four different Morse sequence types Continuous modulation with automatic keying sequence repetition. Transmit one keying sequence only, Transmit repeated keying sequences during a specified interval, Transmit the keying sequence once for every specified interval.

Both versions of the transmitter are equipped with functions for monitoring of carrier, modulation and failure conditions. Flexible control from an attached PC via RS485 or from any remotely connected PC via a dedicated WEB Home Page.

Through the remote control interface, the following parameters may be read and/or programmed:

Carrier frequency - RF power - Modulation type - Morse - Audio or GPS (option) - Modulation depth - Morse tone frequency - Keying rate. Four different Morse messages can be typed in as plain text. Four different Morse sequence types may be selected.

The remote control interface also has a built-in non-volatile memory sufficient for storage of the entire transmitter configuration, and enabling stand-alone un-attended operation. Saving the configuration in solid-state memory is controlled via the PC interface.

In addition to the PC interface, the JTM-30C also offers an optional Remote Control Unit that can be attached via a separate galvanic isolated port to provide simple operation of the transmitter from a remote location. The Remote Control Panel may be connected in chain to more than one location.

Transmitter tuning to match the antenna impedance is a manual procedure. An Auto Tune Unit is offered as an option.

A heater element is installed inside the cabinet to reduce humidity at low temperatures.

PCU, Exciter & HPA

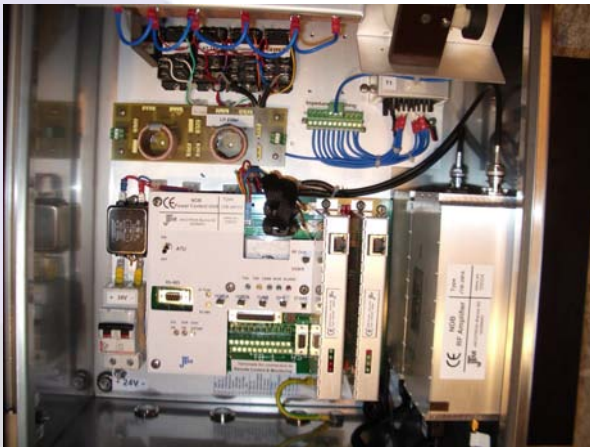

The JTM-30C transmitter consists of one self contained unit, where all system parts except the Power Supply are mounted inside an IP66 weatherproofed and ruggedized cabinet.

The transmitter can be powered from any 24V DC Power Supply capable of supplying up to 15 A. The JTM supplied Power Supplies also provide an interface for battery back up. During an AC Mains failure, the transmitter will automatically be powered from the battery.

ELECTRICAL & MECHANICAL CHARECTERISTICS

Versions of NDB equipment (all-in-one)	:	Single – Dual versions
Antenna Tuning inside Transmitter Cabinet	:	Manual (Autotune Option)
Modules inside Transmitter Cabinet	:	PCU Board, Exciter, HPA and ATU
External units	:	Power Supply and Remote Control(s)
Comply to	:	ICAO and other applicable requirements
Transmitter operates from	:	24V DC +30% / -10%
Protection against	:	Wrong polarity, overvoltage and overheating
AC Power Supply operation from	:	AC mains 115/230 VAC +/-10% and 24V
Ambient operating temperature	:	-35°C to + 55°C
Humidity Transmitter & Power Supply	:	up to 95% at + 40 °C
IP Protection (transmitter)	:	IP66
Frequency range (by synthesizer)	:	190 to 2000 kHz in step of 1 Hz
Frequency stability	:	2,5 p.p.m.
RF Power Output (adjustable)	:	Up to 100 W PEP (into 10 ohm 250 pF)
Harmonic and spurious attenuation	:	More than 60 dB below carrier
Noise and hum attenuation	:	More than 40 dB below carrier
Power consumption (full power)	:	approx. 200W
Antenna impedance (resistance)	:	R = 2 to 25 ohms
Antenna capacity	:	C = 150 to 500 pF
Types of emission	:	A1A, A2A, N0N/A2A, A3E
Modulation tone	:	400/1020 Hz. Any frequency 300-1350 Hz
Audio input for AM voice broadcasting	:	0 dBm 600 ohms with push-to-talk capability
Modulation AM (adjustable)	:	0 to 95%, max 5% distortion
Minimum Shift Keying (MSK)	:	Option (RS-232 and serial input)
Morse Identification code and speed	:	Any combination of code (512 bits), 3 -20 wpm
Morse sequence arrangements	:	Continuous, One time, Once every, Until
Timing / Interval for operation	:	1 minute to 100 minutes
Monitoring and alarms	:	RF output & keying seq., DC failure, TXA / TXB
Remote Control Unit (via wires)	:	ON/OFF/Remote and LEDS for monitoring
Remote Control & Monitoring (from PC)	:	Total control and monitoring via RS-485 Interface, at any distance (up to 2-300m)
Transmitter Dimensions & Weight	:	Height : 600 mm + insulator Width : 400 mm + heat sink 40mm Depth : 320 mm Weight : 33,8 kg (Dual), 31,6 kg (Single)
Transmitter Cable Glands	:	PG16
Power Supply Dimensions & Weight	:	Height : 315 mm Width : 195 mm Depth : 95 mm Weight : 5,6 kg
Power Supply Cable Glands	:	PG21
Remote Control Dimensions & Weight (for installation in 19" Panels)	:	Height : 88 mm Width : 250 mm Depth : 40 mm Weight : 0,3 kg

Subject to change without notice!